

## Tool-less® Vertical Closure With Hydraulically Assisted Davit Installation, Operation, & Maintenance

### CAUTION!

Operating closures can be extremely hazardous and safety precautions must be exercised. Proper installation and maintenance of Tube Turns Tool-less® Closures have a direct bearing on the safety of the operator. All instructions should be read carefully by personnel engaged in installation, operation, and maintenance.

### ORIENTATION

The "V" type closure is designed for installation and operation in the vertical plane (door raises and lowers for opening and closing, respectively). Standard "V" type closures up to size 24" are provided with lifting davits that mechanically raise and lower the door. Larger sizes can be provided with either lifting lugs (requiring an external lifting source) or hydraulically assisted lifting davits. All "V" type closures must be installed truly vertical.

The "H" type closure is designed for installation and operation in the horizontal plane (door swings in and out). The standard hinge orientation is left hand such that the door swings open from right to left. Right hand hinging is also available and must be specified at time of order. The "H" type closure, regardless of left hand or right hand orientation, must be installed truly horizontal.

### WELDING

The closure should be joined to a pipe end or vessel nozzle with a circumferential butt-weld, employing the standard technique most appropriate to the particular installation. The closure hub is equivalent to a short, thin, close tolerance, pipe nipple and all precautions that are normally required in fabrications of this type must be taken.

The welding of nozzles, sight glass frames, structural attachments, etc. to the closure should be done at the factory prior to final machining. If it is necessary to make field welds on the vessel in the vicinity of the closure, they should be made before the closure is attached to the pipe or vessel.

### POST WELD HEAT TREATMENT

When the closure attachment weld must be post weld heat treated, local heat treatment is recommended. Careful control is required during this operation to ensure the closure is not warped. The use of proven procedures is required.

### ATTENTION!

The closure door, seal, and locking ring assembly must be removed before welding and post weld heat treatment.

### OPERATION

#### CAUTION!

Do not attempt to open the closure until all incoming pressure lines have been closed off and the pipe or vessel has been relieved of all internal pressure. Opening under pressure may result in injury to persons and damage to property.

All closures are equipped with a pressure warning screw assembly that prevents the door from being opened while under internal pressure. The pressure warning screw assembly comprises of a pressure warning screw (PWS), safety interlock segment, and connecting arm. The PWS, when loosened under gaseous pressure, will generate a whistling noise to alert the operator that the closure is under pressure. If the pressurizing media is a liquid, the pressure warning screw will leak. The safety interlock segment is connected to the pressure warning screw via the connecting arm and prevents the locking ring from being unlocked while the pressure warning screw is installed.

Opening the closure may be performed safely using the following steps:

- 1) Loosen pressure warning screw (if any pressure or residual fluid is detected, re-tighten the pressure warning screw and do not attempt to continue opening the closure). Ensure all fluid is completely drained before continuing.
- 2) Completely remove pressure warning screw assembly from door.
- 3) Insert actuator handle (attached to closure) into crank from the bottom and rotate 180° counterclockwise. Actuator crank will "snap" as rotation is completed (locking ring completely collapsed).
- 4) Pump hydraulic hand pump handle to raise door completely above hub. Ensure hydraulic pump valve is closed (valve finger rotated clockwise).
- 5) Engage safety chain ring with cylinder bracket hook.
- 6) Swing door away from hub. Do not stand in the way of the door.
- 7) Lightly apply silicone based lubricant (*Dow Corning® 4 Electrical Insulating Compound* is recommended) to sealing faces and contact surfaces.

#### Steps 1 & 2

Loosen PWS and remove assembly.

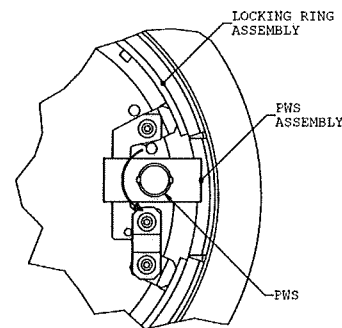

Figure 1

#### Steps 3

Insert handle and rotate 180° PWS counterclockwise.

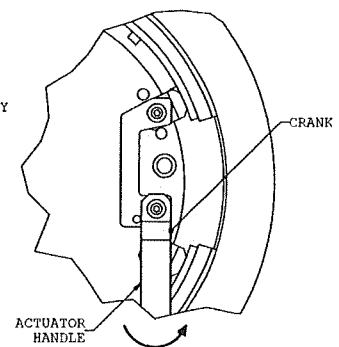

Figure 2

## OPERATION (CONTINUED)

### Step 4

Pump hydraulic hand pump handle. Ensure valve finger is rotated clockwise.

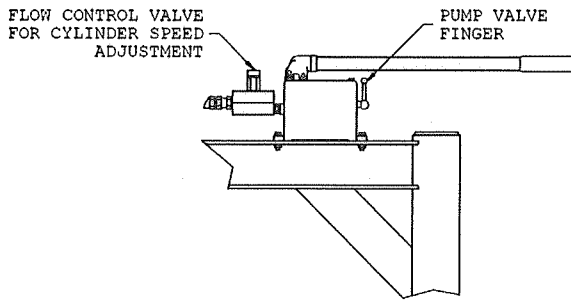

Figure 3

### Step 5

Engage safety chain ring with bracket hook.

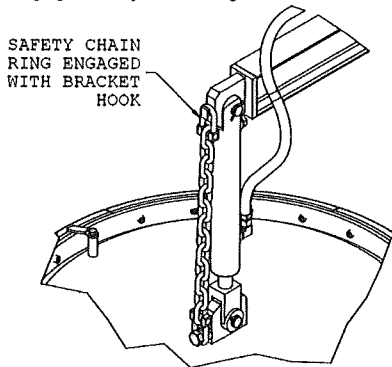

Figure 4

## CAUTION!

Do not place hand between the hub and door while opening or closing the door.

Closing the closure may be performed properly using the following steps:

- 1) Wipe off all sealing faces and contact surfaces and lightly apply silicone based lubricant (*Dow Corning® 4 Electrical Insulating Compound* is recommended). Ensure all deposits and corrosion has been removed.
- 2) Visually inspect seal for any damage including tears, excessive wear, swell, etc. If breaks or tears are present, the seal must be replaced to ensure seal reliability during operation.
- 3) Ensure seal groove in door is free from corrosion. Apply silicone based lubricant (*Dow Corning® 4 Electrical Insulating Compound* is recommended) if necessary.
- 4) Swing door to position directly above hub opening. Do not stand in the way of the door.
- 5) Disengage safety chain ring from cylinder bracket hook.
- 6) Lower door in hub by opening hydraulic hand pump valve (turn valve finger counterclockwise). Door will slowly lower in hub. Ensure door is completely seated inside hub.
- 7) Insert actuator handle (attached to closure) into crank from the top and rotate 180° clockwise. Actuator crank will "snap" as rotation is completed (locking ring completely expanded and locked).
- 8) Insert pressure warning screw into threaded hole in door while placing safety interlock assembly into the locking ring gap.
- 9) Tighten the pressure warning screw to approximately 10 ft.-lb.

## DISASSEMBLY & RE-ASSEMBLY

Door removal may be performed using the following steps:

- 1) Remove the pressure warning screw assembly and collapse the locking ring (see OPERATION section for 'opening' procedure).
- 2) Remove clevis pin that attaches hydraulic cylinder to door lifting lug.
- 3) Retract hydraulic cylinder (door will remain in hub) and swing davit away from door.
- 4) Safely secure hoist lifting hook to door lifting lug. Door is ready to be removed.

Door Re-installation may be performed using the following steps:

- 1) Carefully lower door into hub using hoist.
- 2) Position davit over door center.
- 3) Extend hydraulic cylinder. Attach hydraulic cylinder clevis to door lifting lug with clevis pin.
- 4) Insert cotter pins into clevis pin to lock clevis pin in place.

## PAINT PREPARATION

Perform the following steps before blasting and painting:

- 1) Remove hydraulic components and mask off areas indicated in *Figure 5* and *Figure 6*
- 2) Mask hub and door surfaces making contact with locking ring. Ensure no grit or paint gets between hub and door.
- 3) Once painted, apply a thin layer of *Bostik Never Seez®* (nickel anti-seize lubricating compound) on all hub and door surfaces making contact with locking ring for optimal performance.

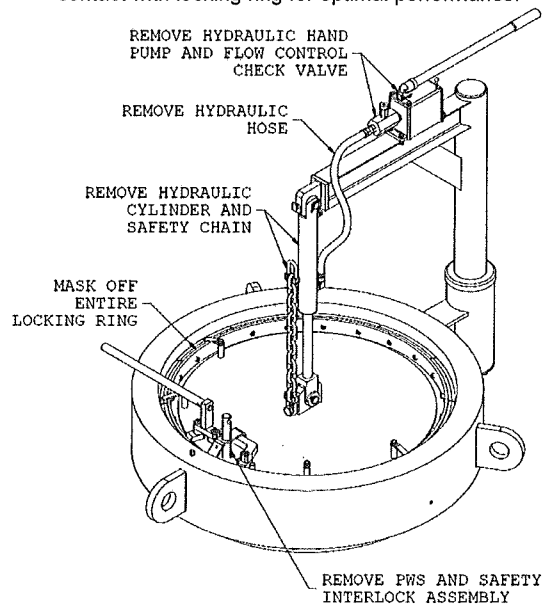

Figure 5 – Parts required to be masked or removed

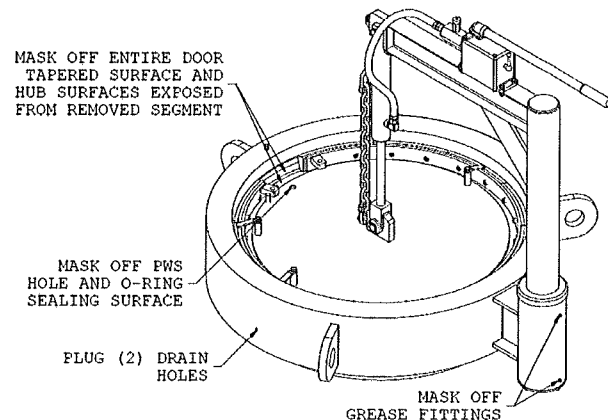

Figure 6 – Areas on hub required to be masked

## GASKET INSTALLATION

There are three important aspects to the installation procedure: 1) Cleaning, 2) Lubrication, 3) Installation.

- 1) **Clean** the door seal groove from all foreign material and corrosion before installing the seal. Foreign material such as grease, oil, dirt, etc. can be removed with a clean cloth and, if required, a solvent. Corrosion can be removed manually with fine emery paper or a wire brush. **DO NOT USE POWER TOOLS ON THE GROOVE/SEALING SURFACES.**
- 2) **Lubricate** the door seal with a thin coat of *Dow Corning® 4 Electrical Insulating Compound* (silicone based lubricant). Too much lubricant on the seal or in the seal groove will prevent proper seating of the seal in the seal groove.
- 3) **Install** the door seal by pushing it into the seal groove at the 12, 3, 6, & 9 O'clock positions per the orientation indicated in *Figure 6*. The seal should be equally distributed about each quadrant. Firmly press in the remaining portions of the seal such that the entire seal is properly seated in the seal groove.

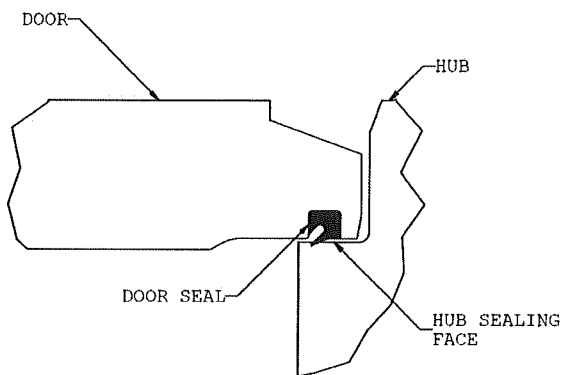

Figure 6 – Seal shown in groove

Closures are shipped with the door seal and o-ring (pressure warning screw seal) already installed.

## MAINTENANCE

**Locking Ring Maintenance** shall include the following:

- 1) Clean surfaces of the locking segments making contact with the head and hub. This may be done easily by opening the door and removing the locking ring assembly.
- 2) Coat contact surfaces with anti-seize compound for optimal performance and rust prevention (*Bostik Never-Seez®* is recommended).

**Door Maintenance** shall include the following:

- 1) Clean the sealing faces ensuring no debris or corrosion is present. Corrosion may be removed by light hand sanding only. Apply light coat of silicone based lubricant (*Dow Corning® 4 Electrical Insulating Compound* is recommended) to faces.
- 2) Clean the tapered surface (making contact with the locking ring segments) ensuring no debris or corrosion is present. Corrosion may be removed by hand sanding only. Apply anti-seize compound (*Bostik Never-Seez®* is recommended) to surface.
- 3) Check for pressure warning screw threaded hole/sealing face for damage. Apply silicone based lubricant (*Dow Corning® 4 Electrical Insulating Compound* is recommended) to sealing face.

## MAINTENANCE (CONTINUED)

**Hub Maintenance** shall include the following:

- 1) Clean the sealing face ensuring no debris or corrosion is present. Corrosion may be removed by hand sanding only. Apply silicone based lubricant (*Dow Corning® 4 Electrical Insulating Compound* is recommended) to face.
- 2) Clean the tapered surface (making contact with the locking ring segments) and fillet groove ensuring no debris or corrosion is present. Corrosion may be removed by hand sanding only. Apply anti-seize compound (*Bostik Never-Seez®* is recommended) to surface.

**Pressure Warning Screw Maintenance** shall include the following:

- 1) Check screw threads for damage. Clean debris from threads and slot. Lubricate the threads with anti-seize compound (*Bostik Never-Seez®* is recommended).
- 2) Remove and inspect the O-ring for damage or wear. Replace if necessary.

**Door Seal Maintenance** shall include the following:

- 1) Inspect the door seal for damage. If noticeable damage is present, the seal must be replaced to ensure safety and reliability.
- 2) To replace the door seal, see section GASKET INSTALLATION.

Note: Seal replacement frequency will depend upon such factors as operating pressure and temperature, shrinkage and swelling caused by product absorption, the corrosiveness of the product in the system and frequency of operation.

## SEAL MATERIAL COMPATIBILITY

**Common Seal Materials** used for seal are discussed below. Technical information as to properties and usages of lip seal material are based on data and recommendations of the manufacturers of the materials.

**Buna-N** is used for general service. Resistant to petroleum-base hydraulic and lubricating oils; animal and vegetable oils; gases such as butane, propane, acetylene, and natural gas, aromatic and non-aromatic fuels such as gasoline, kerosene, diesel fuel and fuel oils; anhydrous ammonia, and water. Temperature limits  $-40\text{ }^{\circ}\text{F}$  to  $250\text{ }^{\circ}\text{F}$ ; special compounds suitable for  $-76\text{ }^{\circ}\text{F}$ .

**Viton** is generally used for high-temperature services. Resistant to synthetic lubricants, petroleum-base products, some chlorinated solvents, benzene, toluene, and many acids and alkalis. Temperature limits  $-40\text{ }^{\circ}\text{F}$  to  $400\text{ }^{\circ}\text{F}$ .

## **ATTENTION!**

**Determination of the compatibility, of the O-ring material is the responsibility of the purchaser.**

## STORAGE

**Closures** are recommended to be stored inside in a protective environment, away from humidity and moisture (to prevent corrosion). If the closure is stored outside, it should be covered and sealed with a plastic tarp.

All unpainted carbon steel surfaces must be coated with rust preventative for long term storage or humid environments. See MAINTENANCE section for proper application of rust preventatives for door and hub unpainted surfaces.

**Seals** must be stored in sealed bags and away from fluorescent light. Shelf lives for Buna-N and Viton are 7 years and 10 years, respectively.

## **SPARE PARTS**

**Start-Up & Commissioning** requires the following spares:

- 1) One door seal per closure
- 2) Two pressure warning screw O-ring per closure

### **Operation**

- 1) Two\* door seals per closure
- 2) Four\* pressure warning screw O-rings per closure

\*These recommendations are for normal service; spare quantities may require adjustment based on service and operating conditions.

**For Spare Parts Orders**, supply the following information:

- 1) Quantity required
- 2) Description
- 3) Part number
- 4) Size and pressure class
- 5) Closure serial number

### **Example:**

Qty: 8

Material: Buna-N Door Seal

Part No.: 53

Size & Class: 36" CL600

Type: V

Serial No.: TL01979

**TOOL-LESS® CLOSURE PARTS LIST**

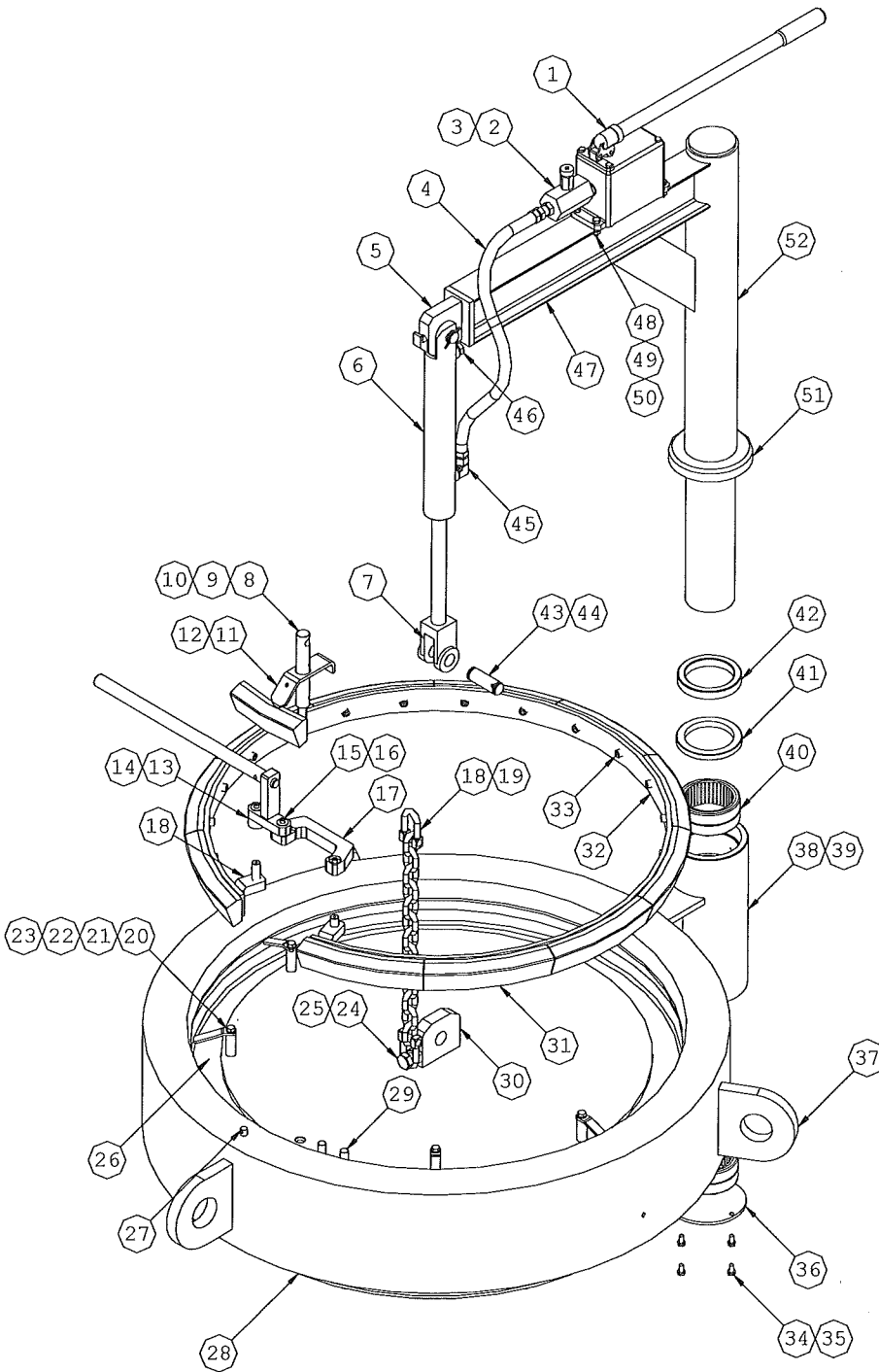

1. Hydraulic Hand Pump
2. Flow Control Check Valve
3. Pipe Swivel Fitting
4. Hydraulic Hose
5. Hydraulic Cylinder Bracket
6. Hydraulic Cylinder
7. Hydraulic Cylinder Clevis
8. Pressure Warning Screw (PWS)
9. PWS O-ring
10. PWS Spring Pin
11. PWS Connecting Arm
12. Safety Interlock Segment
13. Actuator Crank
14. Actuator Crank Spacer
15. Actuator Cap Screw
16. Actuator Washer
17. Actuator U-Plate
18. Safety Chain Shackle
19. Safety Chain
20. Holding Clip
21. Holding Clip Spacer
22. Holding Clip Cap Screw
23. Holding Clip Lock Washer
24. Safety Chain Cap Screw
25. Safety Chain Nut
26. Door
27. Chain Lug
28. Hub
29. Positioning Stud
30. Door Lifting Lug
31. Locking Ring Segment
32. Locking Ring Band
33. Locking Ring Cap Screw
34. Davit Cover Cap Screw
35. Davit Cover Lock Washer
36. Davit Cover, Lower
37. Hub Lifting Lug
38. Davit Socket
39. Davit Socket Grease Fitting
40. Davit Roller Bearing
41. Davit Thrust Ring
42. Davit Thrust Bearing
43. Hydraulic Cylinder Clevis Pin
44. Clevis Pin Cotter Pin
45. 90 Degree Pipe Swivel Fitting
46. Hydraulic Cylinder Breather Vent
47. Davit I-Beam
48. Hand Pump Cap Screw
49. Hand Pump Lock Washer
50. Hand Pump Nut
51. Davit Cover, Upper
52. Davit Post
53. Lip Seal (Not Shown)