



2612 Howard Street
 Louisville, KY 40211 USA
 Phone 502-774-6011
 Fax 502-774-6300
 Website: www.tubeturns.com
 For genuine Tube Turns Closure parts please contact
 factory: ttaftermarket@sypris.com

Bulletin No. TT720
 Revised January 2017

Yoke Type Hinged Closures Installation, Operation & Maintenance

Caution: Operating a closure can be a hazardous activity and certain precautions should be exercised. Proper installation and maintenance of Tube Turns Hinged Closures have a direct bearing on the safety of the operator. All instructions should be read carefully by personnel engaged in installation, operation and maintenance.

Tube Turns Hinged Closures are designed so that the head, hub and yoke are the only pressure containing parts. Proper containment of pressure depends on the O-ring being in place and the head and yokes being completely closed. The nuts and bolts serve the purpose of drawing the yokes into position.

Since a metal-to metal contact between the laps of the head, hub and yoke is a primary requirement for successful and safe operation of these closures, it is imperative that during the installation, maintenance and operations described below that these surfaces be kept clean and dry.

Installation

The H type closure is designed for installation and operation in the horizontal plane (opens like a car door). The standard hinge orientation is left hand such that the head opens from right to left. Right hand hinging is also available; it must be specified at time of order.

The V type closure is designed for installation and operation in the vertical plane (opens like a car hood).

The S type closure may be installed in either the horizontal or vertical plane.

To guard against possibilities of distortion and to protect the contact surfaces from weld spatter, the closure head and yokes should be closed during all welding operations. Closures are shipped with a standard Buna-N O-ring gasket installed which should be removed before any welding on the closure. Special compound O-rings are packed separately. The O-ring should be installed after all attachment welding and stress relieving. The end user is responsible to confirm the O-ring and PWD gasket materials are in good condition and are compatible with the service conditions.

The closure should be joined to the pipe end or vessel nozzle by a circumferential butt-weld, employing the standard technique most appropriate to the particular installation. The closure hub is equivalent to a short, thin, close tolerance, pipe nipple and all precautions that are normally required in fabrications of this type must be taken.

The welding of nozzles, sight glass frames, structural attachments, etc. to the closure should be done at the factory whenever possible. If it is necessary to make field welds on the vessel in the vicinity of the closure, they should be made before the closure is attached to the pipe or vessel.

Stress Relieving/Post Weld Heat Treatment: When the closure attachment weld must be stress relieved, localized stress relief is recommended. Careful control is required during this operation to assure that the fabricator does not warp the closure. The use of proven procedures is required. If care is exercised, localized stress relief can eliminate the need for disassembly and reassembly of the unit.

When it is necessary to stress relieve the entire vessel, the following steps should be taken to prevent distortion of the closure during heat treating: (1) Remove O-ring gasket, (2) Remove the PWD holding nuts and gaskets, (3) Close the head and draw the yoke halves tightly together, (4) Remove the yoke holding bolts and provide substitute bolting, (5) Remove all sealed bearings, (6) Support all structural attachments and, (7) After stress relieving, remove substitute bolting and replace with the original yoke holding bolts. (See **Disassembly and Reassembly** procedures on following pages.)

O-ring Seal: Closures are shipped with a standard Buna-N O-ring installed. Special compound O-ring seals are packed separately. The O-ring should be installed after all welding and stress relieving of the closure is completed.

If it is necessary to perform more than one hydrostatic test, the o-ring should be inspected for damage before each test. If it is damaged, it should be replaced.

The O-ring should be installed per the following procedure which is intended to be a general guide for the installation of O-Ring seals in Tube Turns Yoke Style Double Bolt Closures. Please contact the factory for specific questions or situations not covered by this procedure.

BACKGROUND The O-ring groove used in these closures is a single dovetail, with the dovetail on the ID side of the groove, as shown below. The O-ring diameter is deliberately made smaller than that of the groove into which it will be installed. This puts the O-ring in tension, holding it against the dovetail, which keeps the O-ring in the groove and prevents accidental removal.

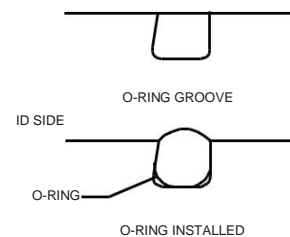

PROCEDURE There are three important aspects to the installation procedure; cleaning, lubrication and uniform installation.

Cleaning - The O-ring groove and the seating surfaces must be free of all foreign material and corrosion before the O-ring is installed. Foreign material such as grease, oil, dirt, etc. can be removed with a rag and, if required, a solvent. Corrosion can be removed, MANUALLY, with a fine emery paper or wire brush. DO NOT USE POWER TOOLS.

Lubrication - The O-ring should be lightly coated with a lubricant such as Vaseline or silicone grease. **WARNING:** too much lubricant on the O-ring or in the groove will prevent proper seating of the O-ring in the groove and possibly lead to premature o-ring failure.

Installation - It is important that the O-ring be installed in the following manner to provide equal distribution of the O-ring in the groove.

a. Push the O-ring into the groove in (4) sequential steps as shown in Figure 1.

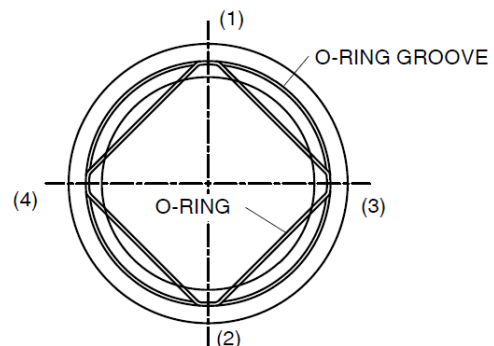

FIGURE 1

b. "Split the difference" between these (4) points and push the O-ring into the groove as shown in Figure 2.

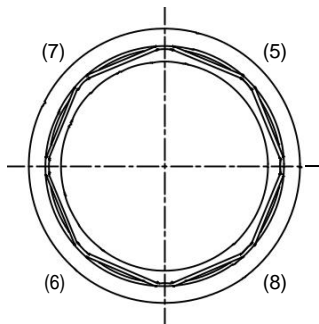

FIGURE 2

c. Complete the installation by pushing the O-ring into the groove in between the initial installation points above. If the O-rings are of a high hardness (90 durometer) or are being installed in cold weather it may be necessary to use a block of soft wood and a small hammer to tap the o-ring into its fully seated position in the groove.

Pressure Warning Device (PWD) Gaskets

The PWD gaskets are labelled as (2) in the parts diagram on the last page of this IOM. The standard material is compressed aramid fiber with a nitrile binder. The end user is responsible to confirm the PWD gaskets are in good condition and are compatible with the service conditions prior to installation and use. The PWD gasket shall be installed by pressing it firmly into the PWD Holding Nut so that it fits flat against the circular surface inside the nut.

Operation Opening

Caution: Do not attempt to open the closure until all incoming pressure lines have been closed off and the pipe or vessel has been relieved of all internal pressure. Opening under pressure may result in injury to persons and damage to property.

The closures are equipped with pressure warning devices which serve a dual purpose. Their primary purpose is as a safety device to prevent the closure from being opened under pressure or pressurized while not being fully closed. If the internal pressure has not been completely relieved in a vessel containing gas, they will produce a whistling sound. Conversely, if the vessel contains a liquid, the Pressure Warning Device will leak when the holding nut is loosened. Their secondary purpose is to assure that the yokes are approximately in the proper location in the closed position. THESE DEVICES ARE NOT BLEEDER PLUGS AND ARE NOT DESIGNED TO RELIEVE INTERNAL PRESSURE OR ACT AS A RELIEF VALVE.

Prior to opening the closure, relieve internal pressure or vacuum in the pipe or vessel.

For H and V type closures open pressure warning devices. Lift positioning plates. Spread the yoke halves by turning both yoke bolts with a hand wrench, either simultaneously or by turning one bolt until it reaches its limit of movement (as indicated by an increase of turning effort) and then turning the other bolt, alternating this procedure. If an impact wrench is used, it must be operated very carefully to avoid uneven tightening that will result in imposing binding action on either of the bolts. This can actually break the smaller yoke bolts and bend the larger yoke bolts.

Caution: If excessive torque is required to turn the bolts after two full turns, internal pressure may still exist in the closure. Stop and check to determine if all internal pressure has been completely relieved from the pipe or vessel.

When both yoke halves clear the flange of the closure head, it may be swung open on its hinge affording full access to the interior.

The springs on the V type closures are intended only to assist the operator in lifting the closure head. Table 1 gives the approximate force required to lift the heads of V type closures (equipped with springs) of various sizes and classes.

For S type closures open pressure warning device and loosen the swing bolt nut with a hand wrench until it will clear the lug. DO NOT USE AN IMPACT WRENCH.

Size In Inches	Type		
	150	300	600
8	3	5	8
10	6	9	14
12	9	14	21
14	11	17	26
16	15	24	36
18	20	31	48
20	26	41	62
22	33	51	78
24	40	64	95
26	49	77	118
28	59	92	141
30	70	110	168
32	82	*	*
36	109	*	*
38	124	*	*
40	141	*	*
42	159	*	*

* Springs are not available. Contact manufacturer for alternate methods of lifting heads.

Closing

For H and V type closures: To close the unit, first inspect the O-ring, O-ring groove and seating surfaces to see that the O-ring is properly in place and remove all foreign material. Swing the head to the closed position, and draw the yoke halves over the head flange by tightening the yoke bolts, turning the bolts either simultaneously or one at a time alternately with a hand wrench. If an impact wrench is used, it must be operated very carefully to avoid uneven tightening that will result in imposing binding action on either of the bolts. This can actually break the smaller yoke bolts and bend the larger yoke bolts. Tighten the y o k e bolts to the torque shown in Table 2. The "splits" between the yokes (top and bottom) should be equal within 1/16" (1.5 mm).

TABLE 2 - RECOMMENDED MINIMUM BOLT TORQUE FOR OPERATING CONDITIONS - INCREASE BY 50% FOR HYDROSTATIC PRESSURE TEST

Closure Nominal Diameter	Class 150		Class 300		Class 600		Class 900		Class 1500	
	Bolt Dia.	Torque (ft-lbs)	Bolt Dia.	Torque (ft-lbs)	Bolt Dia.	Torque (ft-lbs)	Bolt Dia.	Torque (ft-lbs)	Bolt Dia.	Torque (ft-lbs)
8"	5/8"	30	5/8"	30	5/8"	30	3/4"	40	1"	50
10"	3/4"	40	3/4"	40	3/4"	40	1"	50	1 1/8"	90
12"	3/4"	40	3/4"	40	1"	50	1 1/8"	55	1 1/4"	110
14"	3/4"	40	3/4"	40	1"	50	1 1/4"	60	1 1/2"	120
16"	7/8"	45	7/8"	45	1 1/8"	55	1 1/2"	70	1 1/2"	160
18"	7/8"	45	7/8"	45	1 1/4"	60	1 1/2"	80	1 3/4"	250
20"	7/8"	45	1"	50	1 1/2"	80	1 3/4"	100	2"	340
22"	7/8"	45	1 1/8"	55	1 1/2"	80	1 3/4"	120	2"	410
24"	7/8"	45	1 1/4"	60	1 3/4"	100	2"	150	2 1/4"	550
26"	1"	50	1 1/4"	60	1 3/4"	100	2"	170	2 1/2"	700
28"	1"	50	1 1/2"	80	1 3/4"	100	2 1/4"	220	2 1/2"	810
30"	1"	50	1 1/2"	80	2"	140	2 1/4"	260		
32"	1 1/8"	55	1 1/2"	80	2"	140	2 1/2"	320		
34"	1 1/8"	55	1 3/4"	125	2 1/4"	160	2 3/4"	400		
36"	1 1/8"	55	1 3/4"	125	2 1/4"	160	3"	510		
38"	1 1/4"	60	1 3/4"	125	2 1/2"	200	3"	530		
40"	1 1/4"	60	2"	150	2 1/2"	200	3 1/4"	630		
42"	1 1/4"	60	2"	150	2 3/4"	270	3 1/4"	670		

For S closures: To close the unit, first inspect the O-ring, O-ring groove and seating surfaces and remove all foreign material. Swing the head to the closed position, and draw the yoke halves over the head flange. Place the bolt in its locking position and draw the nut to approximately 20 ft-lbs. Tighten the pressure warning device holding nut to 15 to 25 ft-lbs after the positioning plate has engaged the yoke lugs.

For closures with Chain and Sprocket Drive Assemblies: Apply a force of approximately 50 lbs to the single crank arm. If the closure is equipped with a handwheel, apply a force of 50 lbs to each side of the handwheel.

For closures furnished with Secondary Bolt Assemblies: Please follow these instructions: (1) Ensure the primary Yoke Bolts have been assembled to the recommended minimum torque values as listed in Table 2, (2) Assemble the secondary nuts and studs to the secondary yoke bolt lugs and hand tight, and (3) Torque these nuts to 20 ft.-lbs. The nuts only need to be tightened to the point that they will not loosen due to system vibration and environmental factors.

Pressure Warning Devices: PWD gaskets must be installed after each time the closure has been opened. With the gaskets installed, and the threads of the PWD nipple lubricated, tighten the PWD warning device holding nuts to the torque shown in Table 3.

TABLE 3 - RECOMMENDED TORQUE FOR PRESSURE WARNING DEVICE HOLDING NUTS WITH STANDARD PWD GASKETS & LUBRICATED THREADS

PWD NIPPLE SIZE	CLOSURE SIZE & CLASS	TORQUE (FT-POUNDS)
5/8	2"-18" (All Classes)	15-25
7/8	20"-30" (All Classes)	30-40
1	32"-42" (All Classes)	40-55
1 1/4	Various (Special Size/Class)	90-135

Caution: Do not pressurize closure until positioning plates are properly engaged and holding nut has been tightened. If, for any reason, the positioning plates will not close, the yokes are out of adjustment or the closure has been improperly operated or installed and should not be used until the condition is corrected. (See Disassembly and Reassembly procedures on following pages.)

For S closures: To close the unit, first inspect the O-ring, O-ring groove and seating surfaces and remove all foreign material. Swing the head to the closed position, and draw the yoke halves over the head flange. Place the bolt in its locking position and draw the nut to approximately 20 ft.-lbs. Tighten the pressure warning device holding nut to approximately 15 ft.-lbs after the positioning plate has engaged the yoke lugs.

PWS (Pressure Warning Screw) Alternate Design:

Some Double Bolt Closures feature an alternate Pressure Warning system to the PWD. A "Pressure Warning Screw" (PWS) system has been developed for special applications where the standard PWD is not acceptable. A parts diagram of the PWS can be found on the last page of this IOM.

The PWS features a threaded post captured by a positioning plate assembly that assembles over the positioning lugs. An O-ring located below the threads provides a reliable seal. A secondary O-ring above the threads serves as a weather seal to shed rainwater and prevent ingress of foreign material.

The PWS works in the same manner as the PWD, providing the end user the ability to verify that there is no internal pressure before attempting to open the closure. A "T" handle allows the PWS to be installed and seal without the use of a tool as the handle only needs to be tightened by hand.

Maintenance

O-Ring Seal: The O-ring should be inspected prior to every closing. Variations in service conditions will determine its useful life.

Frequency of replacement will depend upon such factors as operating pressure and temperature, shrinkage and swelling caused by product absorption, the corrosiveness of the product in the system and frequency of operation.

The materials most often used for closure O-rings are discussed below. Technical information as to properties and usages of gasket material are based on data and recommendations of the manufacturers of the materials. Determination of the compatibility of the O-ring material is the responsibility of the purchaser or end user of the closure.

"Buna-N"- General Service. Resistant to petroleum-base hydraulic and lubricating oils; animal and vegetable oils; gases such as butane, propane, acetylene, and natural gas, aromatic and nonaromatic fuels such as gasoline, kerosene, diesel fuel and fuel oils; anhydrous ammonia, and water. Temperature limits **-30 °F to 250 °F**; special compounds suitable for **-65 °F**.

"Fluoroelastomer (FKM)" - Generally Used for high-temperature services. Resistant to synthetic lubricants, petroleum-base products, some chlorinated solvents, benzene, toluene, and many acids and alkalis. Temperature limits **-15 °F to 400 °F**.

"Ethylene Propylene" - Superior resistance to phosphate-ester type fluids, Skydrol, Pydrol, Cellulubes and glycol type coolants. Excellent resistance to mild acids and alkalis. Can be used in steam service, replacing butyl rubber in most applications. Temperature limits **-70 °F to 250 °F**.

"Silicone Rubber"- Good resistance to high and low temperature dry gases, air, oxygen and ozone. May be satisfactory in high-aniline oils, but not recommended for use with most petroleum base products. Temperature limits **-65 °F to 450 °F**.

PWD Gaskets: The gaskets in each PWD Holding Nut shall be replaced each time the nut is loosened. Prior to reinstalling the holding nut, the new gasket shall be installed by pressing it firmly into the nut so that it fits flat against the circular surface inside the nut.

PWS O-rings: The O-ring seals associated with the PWS must be inspected prior to every closing. Variations in service conditions will determine its useful life. Care must be taken when installing the weather seal O-ring to the PWS post to ensure that the O-ring is not damaged by the threads. Use of an O-ring installation tool that assembles over the threads is preferred.

Nuts and Bolts: Both the yoke bolts and nuts should be inspected periodically for thread wear as follows: Measure and record the diameter of both bolts at either end of the bolts. This is most easily done before the closure is opened. This measurement should be taken fairly accurately using a micrometer or caliper in an area where no wear or corrosion has occurred. Measure the diameter of the yoke bolts in the area where the nuts are positioned when the closure is closed. Compare these dimensions to those previously taken. If the wear exceeds 0.030", the yoke bolt unit should be replaced. It is usually recommended that the yoke bolt units be replaced in pairs. Service life of these components is governed primarily by frequency of operation, the care employed in operating the closure, and the use of lubricant.

BOTH NUTS AND BOLTS ARE OF SPECIAL DESIGN AND COMPOSITION. REPLACEMENTS MUST BE IN ACCORDANCE WITH THE SPECIFICATIONS OF THE MANUFACTURER.

Caution: The tapered contact surfaces of the yokes, head and hub must never be painted or coated with a heavy lubricant since this can reduce the effectiveness of the inherent holding characteristics of the closure. These surfaces must be clean, dry and smooth. A protective coating of light oil on these surfaces is permissible. If rusting occurs, it should be removed with a wire brush.

Paint: If the closure is to be painted this should be done with the head in the closed position to prevent paint from being applied to the contact surfaces of the head and hub and inside surfaces of the yokes. The yoke bolts should not be painted.

Lubrication: A good grade of lubricant should be applied periodically to the head hinge bushings, yoke bolt bushings and yoke rollers. If the closure is equipped with a chain and sprocket drive for the yoke bolts, the bearings and the chain(s) should be periodically lubricated with a good grade of either grease or oil as appropriate.

The yoke bolts are rust-proofed and lubricated at the factory by application of a coat of fluorocarbon film. Lubricate the bolts periodically with a hydrocarbon-base lubricant in accordance with the frequency and severity of the service involved. Care should be exercised to avoid getting excess lubricant on the laps of the hub and head or into the yoke cavities.

The threads of the PWD nipples should be lubricated prior to retightening the PWD holding nut. A regular grade anti-seize compound may be used for this purpose.

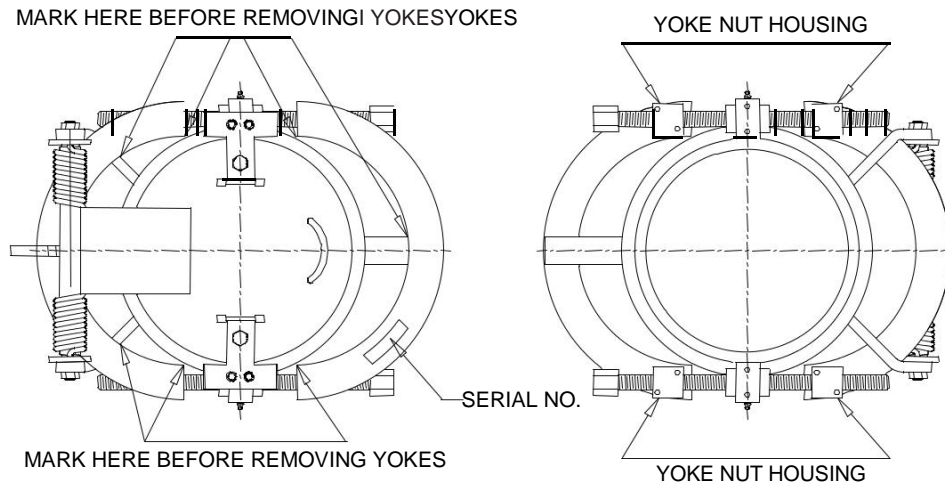

Disassembly Procedure: Numbers in () refer to Parts List on following page. Before commencing disassembly, be sure to observe the warning and precaution under Operation.

A. Open yokes (3) until inside edges touch outside diameters of the closure head as shown in the front view above. Mark position of yokes on hinge arms (16) and (17), support arm (25), and hub (1) as shown.

B. When closure is to be completely disassembled it is recommended that head, hub and yoke be marked as shown in sketch below with a different letter for each closure.

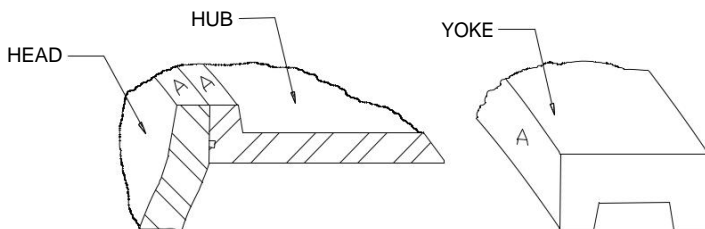

C. Remove cover plate cap screws (15), cover plates (14), bolt holder cap screws (6), and the loose half of the bolt holders (5).

D. Remove yoke bolts (11) without disturbing position of yoke bolt nuts (9) and (10). If there is a possibility that these nuts will be moved or removed, measure or mark each nut location on the yoke bolt so that the nuts can be reset in same position when assembled. If more than one closure of the same size is to be disassembled at the same time, it is suggested that each yoke bolt be tagged with the serial number located on the front raised pad of the yoke or on the ASME nameplate. All other hardware removed, such as cap screws, cover plates, bolt holders, etc., should be boxed and also marked with the serial number when more than one closure of the same size is disassembled at the same time.

E. Horizontal - After removing yoke bolts, the yokes may be removed and set aside. To remove head, first open head back against head stop (22), restrain the adjusting plate (29), remove lock screws (30), remove the hinge rod nuts (21), and then push the hinge rod (20) through the hinge arms (16) and (17). Ease the head off slowly so as not to damage the hinge bearings (19).

E1. Vertical - After removing yoke bolts, the yokes may be removed and set aside. To remove the head (2), first remove the hinge rod nuts (21) and lock washers (22) and then push the hinge rod (20) through the hinge arms (16) and (17). Ease the head off slowly so as not to damage the hinge bearings (19).

Reassembly Procedure: During reassembly, care must be exercised that all components are properly aligned before operating the closure. Misalignment can cause excessive wear and leakage

A. Horizontal - Install head in correct position on the same closure from which it was removed. This can be checked by comparing letters on the head and hub flange since each should have the same letter in the same position for correct alignment as shown in the sketch above.

A1. Vertical - Install head in correct position on the **same** closure from which it was removed. This can be checked by comparing letters on the head and hub flange since each should have the same letter in the same position for correct alignment as shown in the sketch above. Align the hinge tube (18) with the hub hinge arms; and install the hinge hardware; the hinge bolt nuts should be wrenched up snug to prevent head sag.

Align the hinge tube (18) with the hub hinge arms; check to see that the springs (27) and (28) are in their correct positions with the "ear" under the head hinge arm (23) and the other "ear" inserted in a hole in the adjusting plate (29). Insert the hinge rod and set screws and, with the head in the full open position, insert the lock screws (30) into the adjusting plates. To get optimum head balance, spring torque can be adjusted by rotating the adjusting plates with a wrench before inserting lock screws. This adjustment should be performed with the head in the open position.

B. Place yokes in correct position on the same closure on previous marks made on the hinge arms and support arms. Each half of the yoke is marked at the split (as shown in the sketch) with the same letter as the hub and head flanges and the yokes should be placed so that this letter is in the same general area as the letters on the hub and head flanges.

C. Install yoke bolts with wrench lugs (12) on side opposite hinge. The nuts on the bolts should be in the same relative position as originally determined by marking or measurement. After the nuts are placed in the yoke nut housings on the yokes, replace the cover plates, bolt holders, etc.

D. Tighten the yoke bolts and draw the yokes up to the closed position. If unusual effort is required to turn the yoke bolts or one of the yoke halves does not close as far as the other half, then it is likely that one of the yoke nuts (9) and (10) has been turned from its original position. An inspection of the relative position to these nuts will reveal which one should be repositioned to obtain proper operation. (See also, under **Operation**, precautions against uneven tightening of bolts.) As a final check, approximate distance between yoke halves at the yoke splits should be equal.

Yoke Type Closures Parts List

Type H Double-Bolt Horizontal

- | | | | |
|----------------------|---------------------------|---------------------------|---|
| 1. Hub | 9. Nut (RH) | 17. Hub Hinge Arm (Lower) | 25. Support Arm |
| 2. Head | 10. Nut (LH) | 18. Hinge Tube | 26. O-Ring |
| 3. Yoke | 11. Yoke Bolt | 19. Hinge Bearing | 27. Pressure Warning
Device and Positioning
Plate - see last page |
| 4. Bolt Holder (W) | 12. Wrench Lug | 20. Hinge Rod | 28. Positioning Lugs |
| 5. BoltHolder(L) | 13. WrenchLugPin | 21. HingeRodNut | |
| 6. Cap Screws | 14. Cover Plate | 22. Lockwasher | |
| 7. Yoke Bolt Bushing | 15. Cap Screws | 23. Head Hinge Arm | |
| 8. Collar | 16. Hub Hinge Arm (Upper) | 24. Head Handle | |

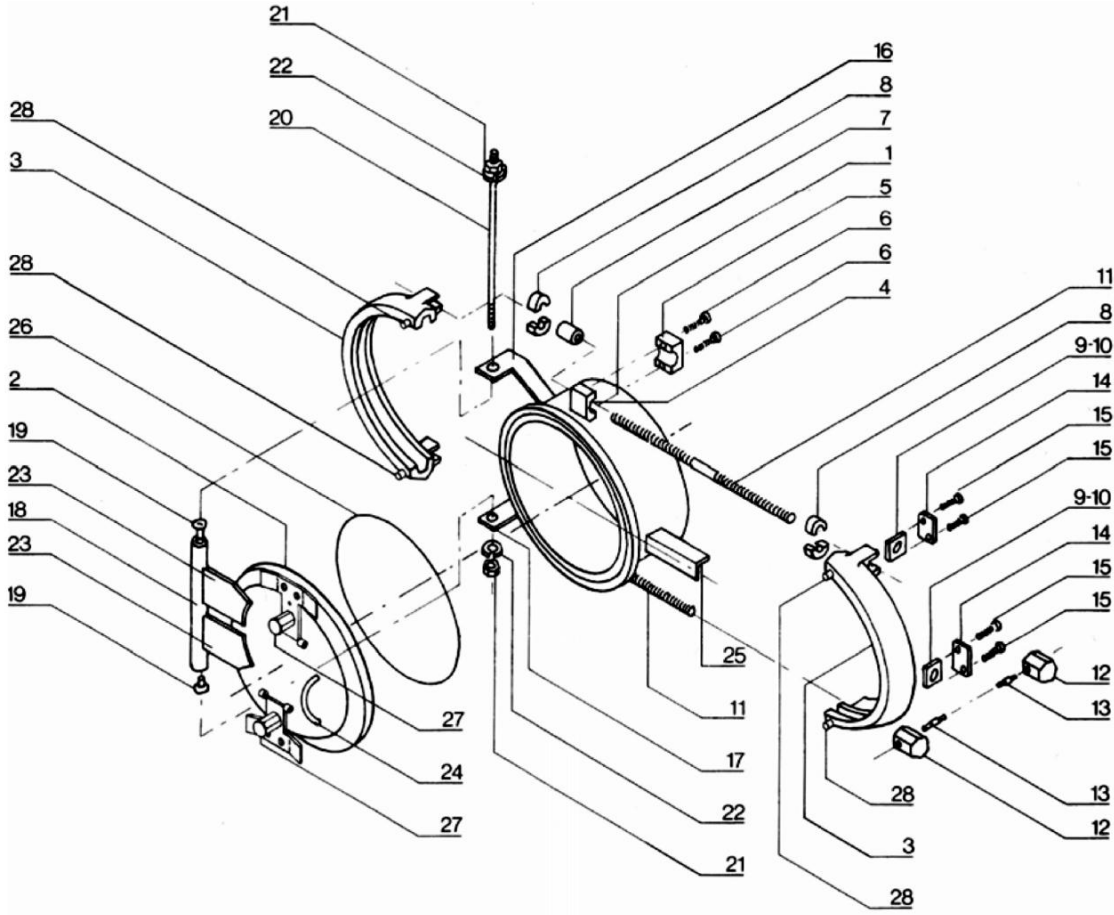

Yoke Type Closures Parts List

1. Hub
2. Head
3. Yoke
4. Bolt Holder (W)
5. Bolt Holder (L)
6. Cap Screws
7. Yoke Bolt Bushing

8. Collar
9. Nut (RH)
10. Nut (LH)
11. Yoke Bolt
12. Wrench Lug
13. Wrench Lug Pin
14. Cover Plate

Type V Double-Bolt Vertical

15. Cap Screws
16. Hub Hinge Arm (RH)
17. Hub Hinge Arm (LH)
18. Hinge Tube
19. Hinge Bearing
20. Hinge Rod
21. Hinge Rod Nut

22. Stop Arm
23. Head Hinge Arm
24. Head Handle
25. Support Arm
26. O-Ring
27. Spring (RH)
28. Spring (LH)

29. Adjusting Plate
30. Lock Screw
31. Pressure Warning Device and Positioning Plate
32. Positioning Lugs

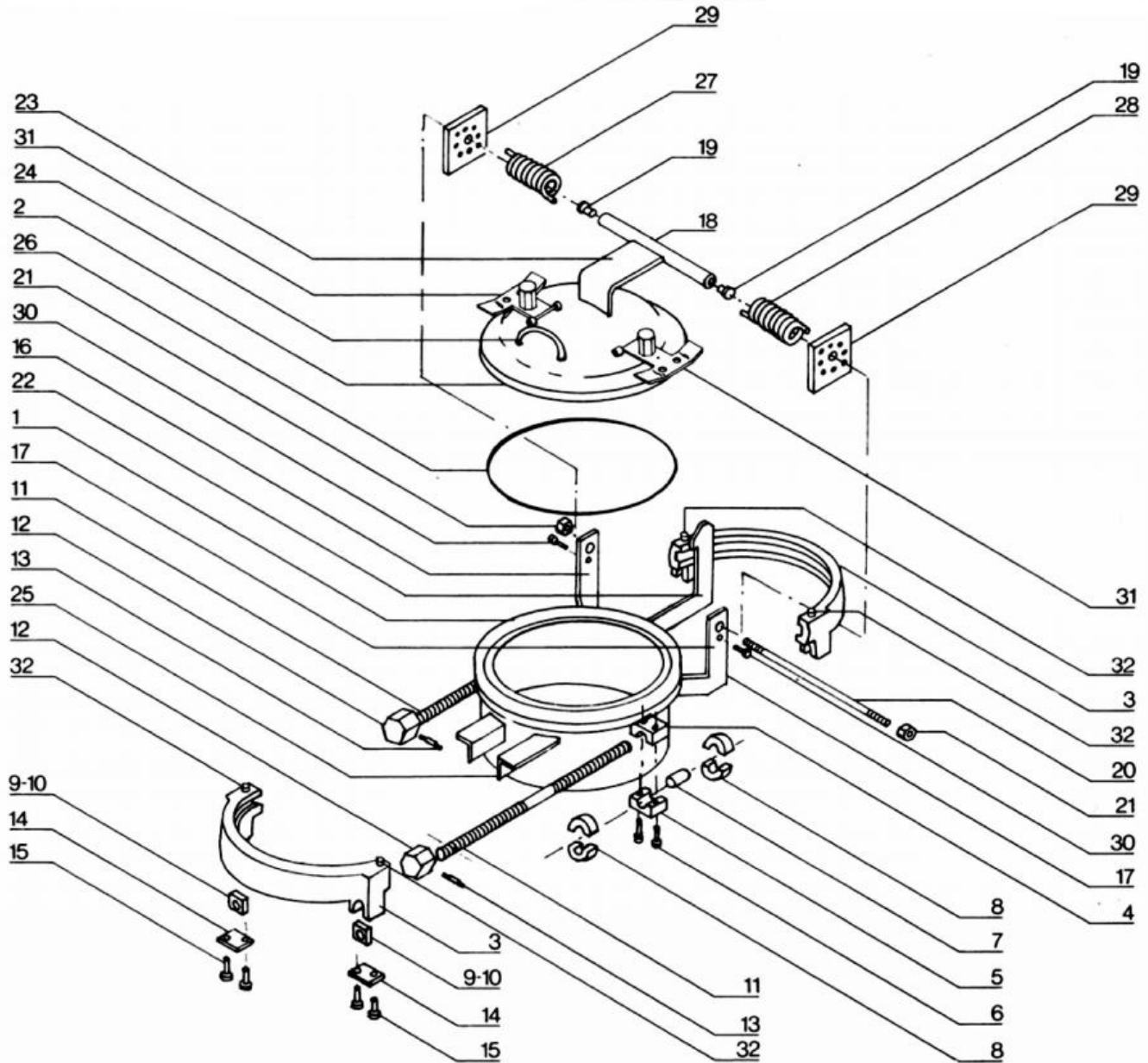

Yoke Type Closures Spare Parts Recommendations

1. START UP AND COMMISSIONING

- a. O-Ring Seals (Part No. 26) – One o-ring seal should be stocked for each closure for a quantity of three or less. For quantities greater than three add one seal for each increment of three.
- b. Pressure Warning Device (PWD) Gaskets – Four PWD gaskets should be stocked for each closure.

2. OPERATION

- a. O-Ring Seals (Part No. 26) – Two O-ring seals should be stocked for each closure. If several identical closures are in operation in a given area, one o-ring per closure may be stocked.
- b. Yoke Bolt Units (Consisting of Part No's 7, 8, 9, 10, 11, 12 & 13) - Two Yoke Bolt units should be stocked for each closure. If several identical closures are in operation in a given area, two Yoke Bolts units may cover as many as three closures. For quantities greater than three add two Yoke Bolt units for each increment of three.
- c. Pressure Warning Device (PWD) Gaskets (Part No. 2 of PWD parts breakdown) – Four PWD gaskets should be stocked for each closure.

3. These recommendations are for normal service; the frequency of opening, extreme environmental conditions and amount of maintenance may require adjustments, either up or down, in the quantities of spares stocked.

When ordering spare parts, give amount, description, part number and size, pressure class and serial number of closure (located on front of yoke or ASME nameplate).

Example: (1) Buna-N O-ring - Part Number 26 - 8" CL 600 - S/N 13845

Type S/Swing-Bolt Parts List

Disassembly & Reassembly

1. Hub	5. Hinge Pin (2" thru 6")	8. Hinge Eye Bolt	11. Swing Bolt Nut	15. PWD - see last page
2. Hub Hinge Lug	5A. Hinge Bolt (8" only)	9. Cotter Pin (2" thru 6")	12. Swing Bolt Pin	16. Positioning Lugs
3. Head	6. Yoke (Upper)	9A. Eye Bolt Nut (8" only)	13. O-Ring	17. Swing Bolt Washer
4. Hinge Arm	7. Yoke (Lower)	10. Swing Bolt		

As indicated by examination of the exploded view, removal of the hinge bolt permits quick and easy disassembly of the hinged closure. The components may be removed in sequence most convenient for the specific job. During disassembly, however, each part should be clearly marked so that it can be replaced in the same relative position and on the same closure unit. This is particularly important when more than one closure of the same size is to be disassembled.

During reassembly, care must be exercised to insure that all components are properly aligned before operating the closure. Misalignment can cause excessive wear and leakage.

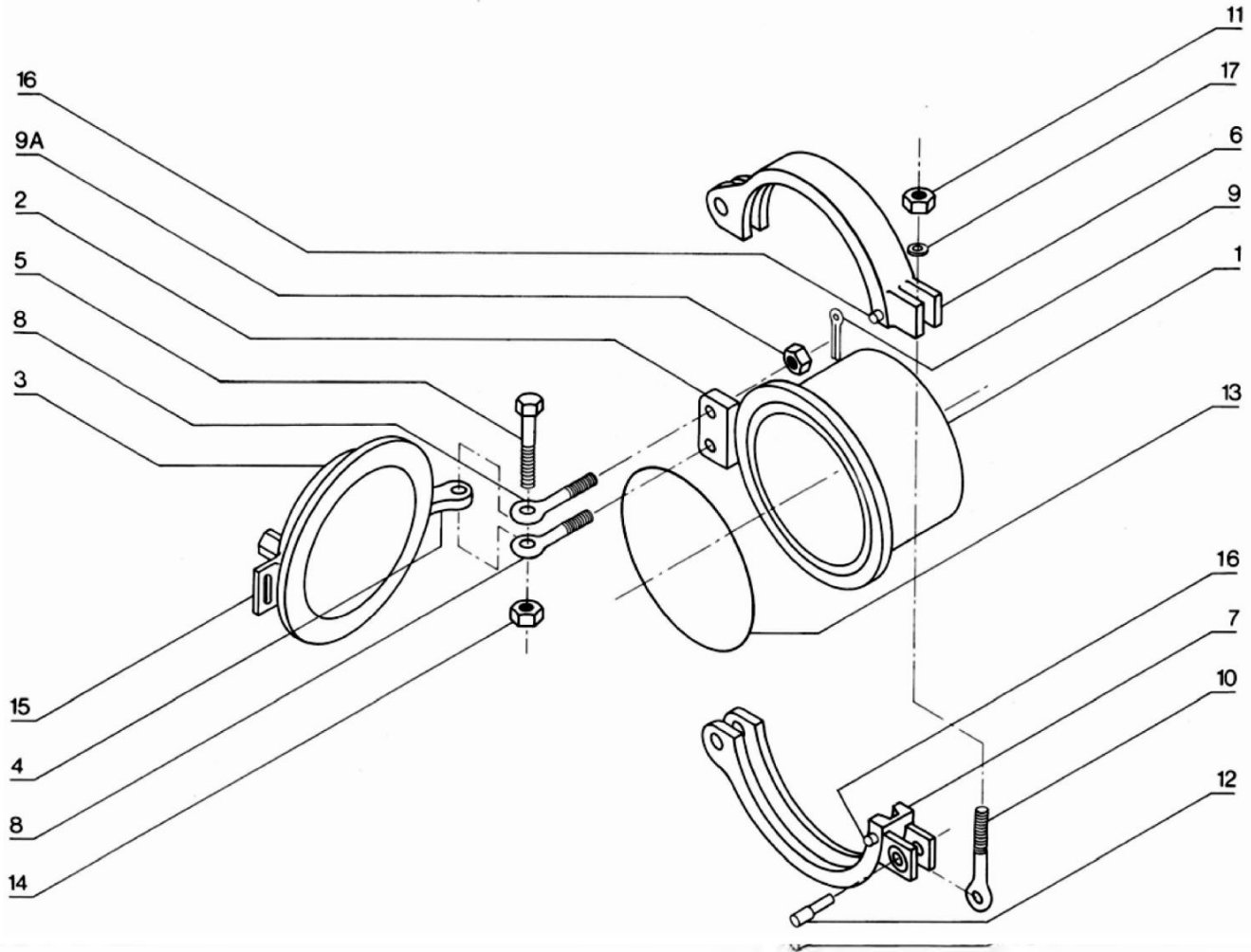

S/Swing-Bolt Spare Parts Recommendations

1. START UP AND COMMISSIONING

- O-Ring Seals (Part No. 13) – One o-ring seal should be stocked for each closure for a quantity of three or less. For quantities greater than three add one seal for each increment of three.
- Pressure Warning Device (PWD) Gaskets – Four PWD gaskets should be stocked for each closure.

2. OPERATION

- O-Ring Seals (Part No. 26) – Two O-ring seals should be stocked for each closure. If several identical closures are in operation in a given area, one o-ring per closure may be stocked.
- Pressure Warning Device (PWD) Gaskets (Part No. 2 of PWD parts breakdown) – Four PWD gaskets should be stocked for each closure.

3. These recommendations are for normal service; the frequency of opening, extreme environmental conditions and amount of maintenance may require adjustments, either up or down, in the quantities of spares stocked.

When ordering spare parts, give amount, description, part number and size, pressure class and serial number of closure (located on front of yoke or ASME nameplate).

Example:(1) Buna-N O-ring - Part Number 13 - 8" CL 600 - S/N 13845

**Pressure Warning Device
Parts List**

- | | |
|----------------|----------------------|
| 1. Holding Nut | 4. Plate Stop |
| 2. Gasket | 5. Positioning Plate |
| 3. Nipple | 6. Hinge Pin |

**For Yoke Type
Closures**

- | |
|---------------------|
| 7. Hinge |
| 8. Positioning Lugs |

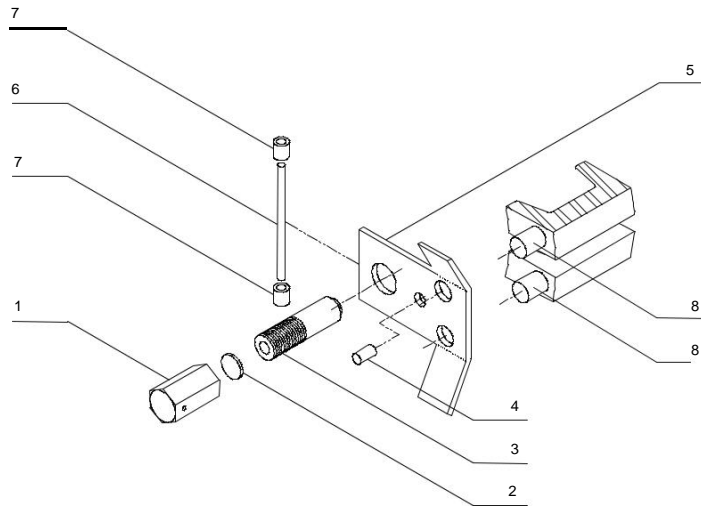

**Pressure Warning Screw
Parts List**

- | | |
|-------------------|-----------------|
| 1. PWS Post | 4. Weather Seal |
| 2. PWS T-Handle | 5. Yoke |
| 3. PWS Plate Assy | 6. O-ring |

**For Yoke Type
Closures**

- | |
|---------------------|
| 7. Positioning Lugs |
|---------------------|

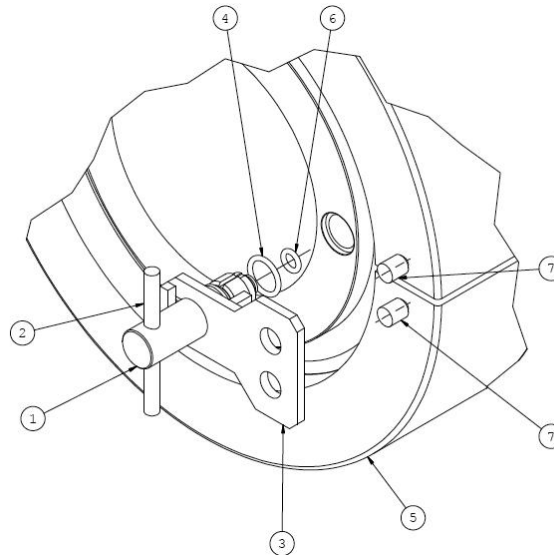

2612 Howard Street
 Louisville, KY 40211 USA
 Phone 502-774-6011
 Fax 502-774-6300
 Website: www.tubeturns.com
 For genuine Tube Turns Closure parts please contact
 factory: ttaftermarket@sypris.com

Bulletin No. TT720
 Revised January 2017

The information contained herein is based on data and information developed in the laboratories of Sypris Technologies ("Seller"), but is presented without guarantee or warranty, and the seller disclaims any liability incurred from the use thereof. Nothing contained herein is to be construed as a recommendation for any use, including, without limitation, any use in a commercial process not controlled by seller, nor for a use which is in violation of any existing patent, foreign or domestic or of applicable laws and regulations.

TUBE TURNS is a trademark of Sypris Technologies, Inc.